

REV	POSITION	DATE	DESCRIPTION

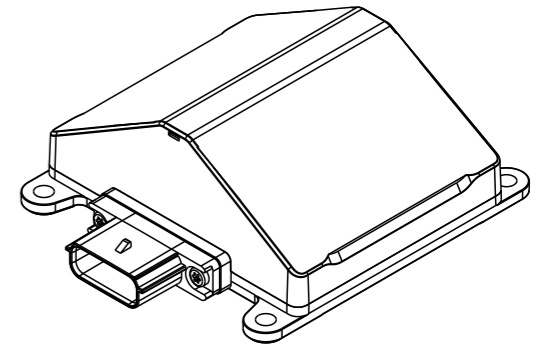
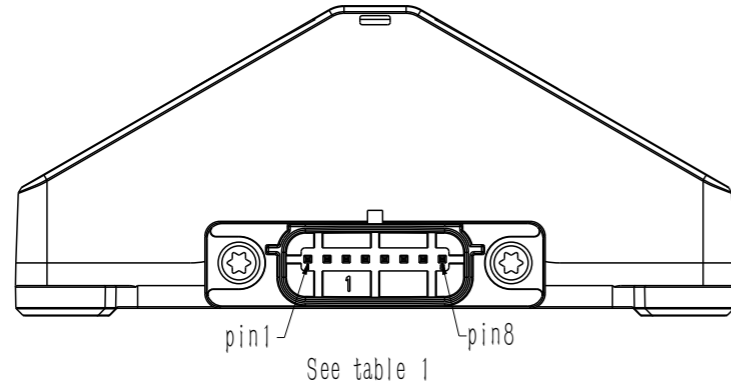
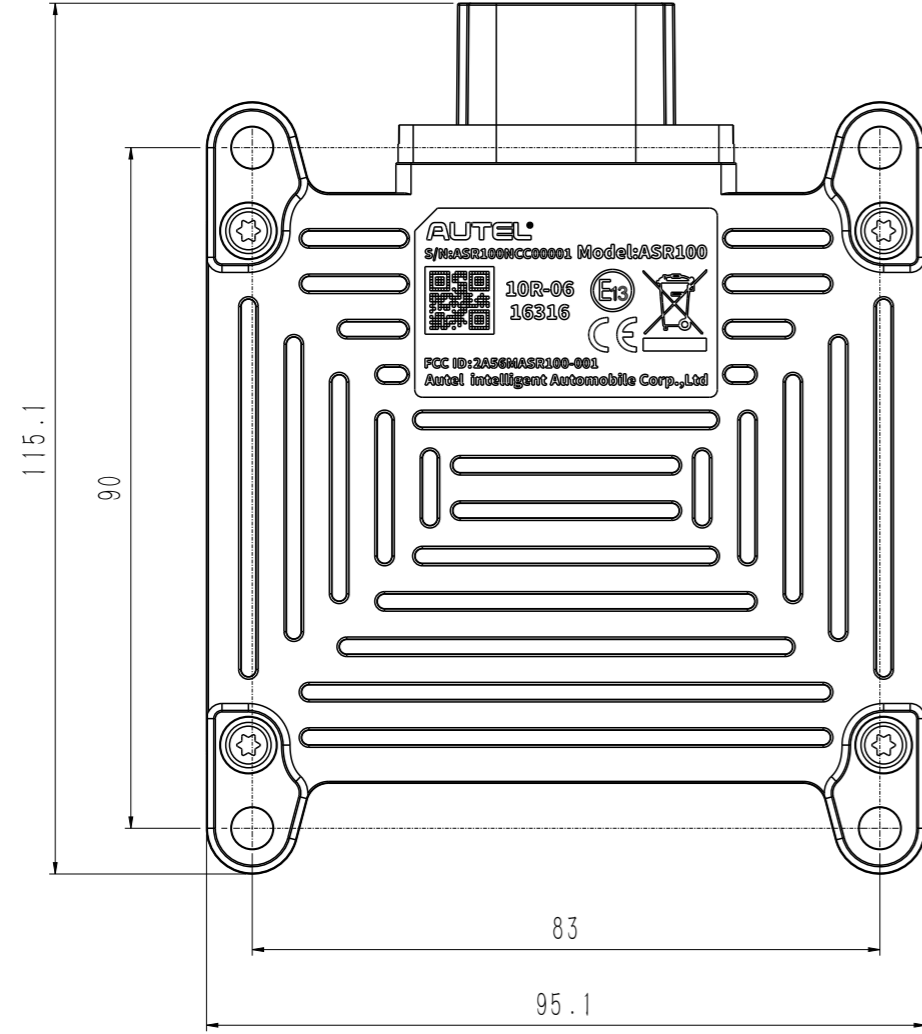
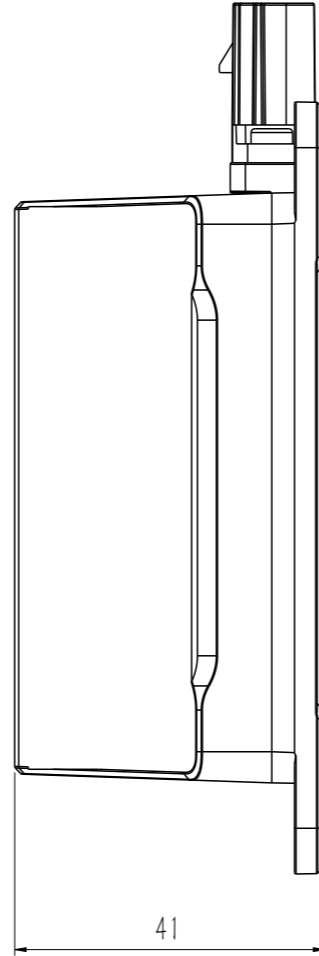

Table 1: Definition of Radar Interface

No.	Definition	Range	Cable color
1	VCC	8~32V DC	Red
2	NC	empty	Orange
3	SWITCH	Input: 12/24V DC Output: 0V DC	Blue
4	GND	0V DC	Black
5	CAN2.0_H	-58~58V DC	Green
6	CAN2.0_L	-58~58V DC	Yellow
7	CAN_FD_H	-58~58V DC	White
8	CAN_FD_L	-58~58V DC	Violet

Table 2: Information

Product number	105000021
Software version	ASR101_TA_ABE_V1.1.13
Operating voltage	8~32V
Max current	0.9A
Operating temperature	-40~85℃
Storage temperature	-40~105℃
Protection rating	IP69K
EOL test	Yes



DIM	±TOL		
	Plastic	Sheetmetal	Machining
0~30	0.20	0.15	0.10
30~120	0.35	0.25	0.15
120~300	0.65	0.35	0.20
300~600	1.10	0.50	0.25
600~1200	1.75	0.60	0.30
>1200	2.10	0.80	0.50
ANG	/	1°	30'

**AUTEL** 道通科技股份有限公司  
Autel Intelligent Technology Corp., Ltd.

These Drawings And Specification  
Are The Property Of AUTEL. And Shall  
NOT Be Reproduced Copied Or Used  
In Any Manner Without The Prior  
Written Consent Of AUTEL.

PROJ

TITLE:		Lateral Radar	
DRAW: JianBing Zhang	UNIT'S: mm	DWG NO.:	
CHKD: Haibin Lu	FINISH: /	LATERAL RADAR	
STAD: Guangping Ou	MASS(Kg): [0.25]	PART NO.:	REV
APPD: Dengguo Zhang	SCALE: 1:1	105000021	V1
SHEET: 1 OF 2	PRODUCT: ASR100	MATERIAL: PBT+30%GF/ADC12+S1	

RELEASE LEVEL: I  
FILE NAME: 0-ASR100-ALL\_ASM\_I31

# AUTEL®

## S/N:ASR100NCC000001 Model:ASR100

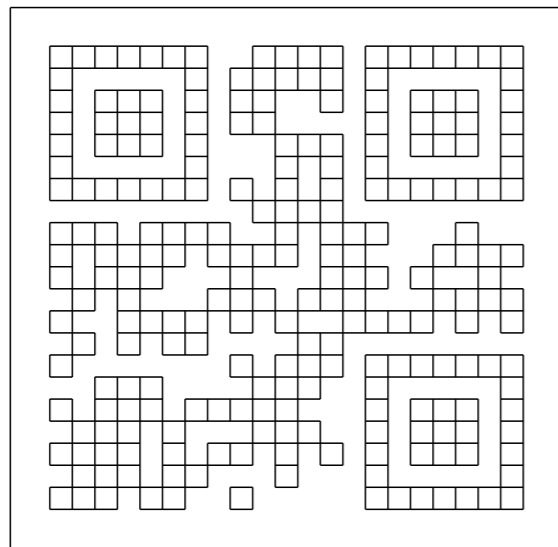

### 10R-06 16316

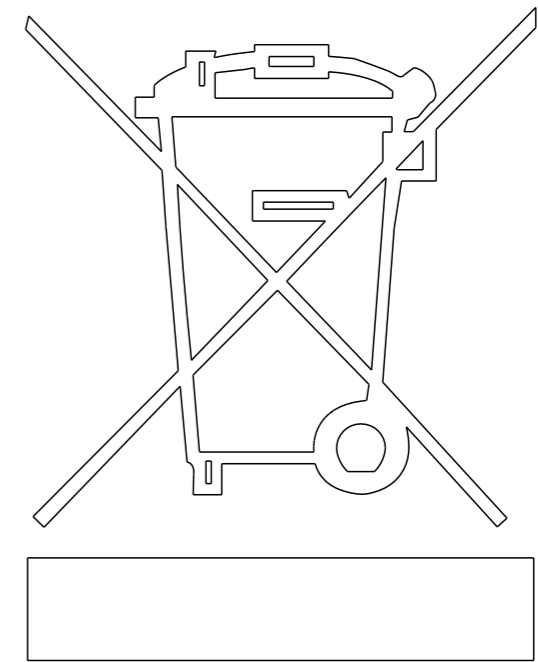
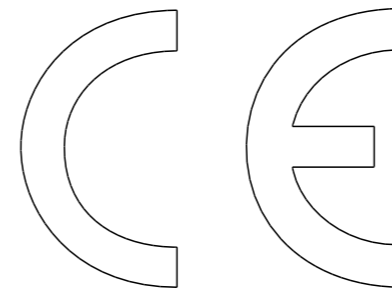

### FCC ID:2A56MASR100-001

### Autel intelligent Automobile Corp.,Ltd

REV	POSITION	DATE	DESCRIPTION

RELEASE LEVEL: 1  
FILE NAME: 0-ASR100-ALL\_ASM\_L31

DIM	±TOL			AUTEL 道通科技股份有限公司 Autel Intelligent Technology Corp., Ltd.	TITLE: LABEL				
	Plastic	Sheetmetal	Machining		DRAW: Jianbing Zhang	UNIT'S: mm	DWG NO.: LABEL		
0~30	0.20	0.15	0.10	These Drawings And Specification Are The Property Of AUTEL. And Shall NOT Be Reproduced Copied Or Used In Any Manner Without The Prior Written Consent Of AUTEL.	CHKD: Haibin Lu	FINISH: /	PART NO.: 105000021		REV
30~120	0.35	0.25	0.15		STAD: Guangping Ou	MASS(Kg): [0.00]			VI
120~300	0.65	0.35	0.20		APPD: Dengguo Zhang	SCALE: 8:1	MATERIAL: PBT+30%GF/ADC12+S1		
300~600	1.10	0.50	0.25		SHEET: 2 OF 2	PRODUCT: ASR100			
600~1200	1.75	0.60	0.30		PROJ				
>1200	2.10	0.80	0.50						
ANG	/	1°	30'						